

ECLIPSE LED LIGHTBAR (LAP2314AC/ECO)

R10

1 YEAR WARRANTY

Our Eclipse LED lightbar features tough polycarbonate lenses and the latest generation LEDs with advanced optics.

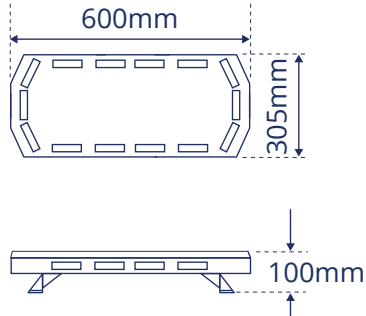

Main Features

- Dual Voltage (12/24V)
- 56 x 1W amber LEDs
- 10 flash patterns
- Polycarbonate lens with aluminium base

MINI LED LIGHTBARS (LAP0930 Range)

R10

2 YEAR WARRANTY

The economical low profile LAP0930 range provides ultra bright hazard warning with 30 x 1W amber LEDs.



Model shown: LAP0930AC/MAG

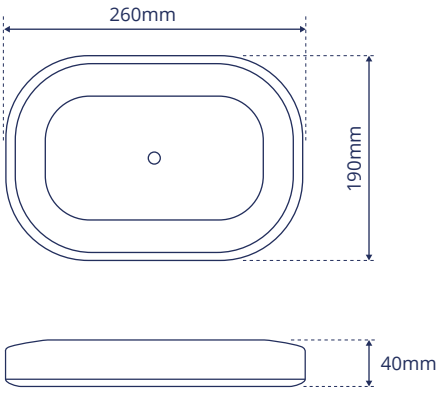

Main Features

- Dual Voltage (12/24V)
- IP56 rated ingress protection
- 40mph rated on magnetic version
- 11 flash patterns
- Clear polycarbonate lens

Part No	No. of Modules	No. of LEDs	LED Rating	Mounting
LAP0930AC/MAG	10	30	1W	Magnetic
LAP0930AC/SP	10	30	1W	Single Point