

# ROTATING BEACONS



LAP Electrical Limited is a firmly established name in the manufacture of emergency lighting beacons.

Our popular range of rotating beacons are designed to provide superior light output for maximum visibility.



### Main Features

- 12V or Dual Voltage (12/24V) options
- 70mph rated on magnetic version
- IP56 rated ingress protection
- Current consumption: 4.6A @ 12V / 3.0A @ 24V
- -30°C to +50°C extreme temperature reliability
- Unique maintenance free direct drive mechanism provides low noise operation

### Lens Colours Available

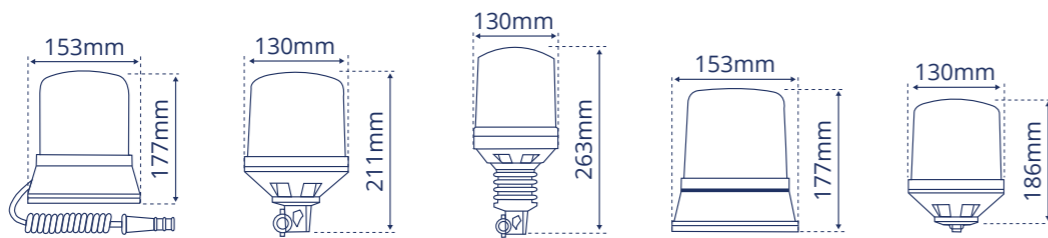

12V Model	<b>LAP259</b>	<b>LAP269</b>	<b>LAP271</b>	<b>LAP254</b>	<b>LAP121</b>
12/24V Model	<b>LAP260</b>	<b>LAP270</b>	<b>LAP272</b>	<b>LAP255</b>	<b>LAP122</b>
Fitting	Magnetic	DIN	Flexi DIN	3 Point	Single Point
Weight	1.1KG	0.8KG	0.8KG	0.5KG	0.7KG

ECE R65 Approval is appropriate to rotating beacons with either an Amber or Blue lens fitted. 12/24V Units are supplied without bulbs.

# ROTATING BEACONS (RMB Range)



Our economical range of R65 approved rotating beacons are reliable and durable.



### Main Features

- Dual Voltage (12/24V)
- 40mph rated on magnetic version
- IP56 rated ingress protection
- Supplied with 12V and 24V bulbs
- -15°C to +40°C extreme temperature reliability
- Maintenance free worm drive mechanism

### Lens Colours Available

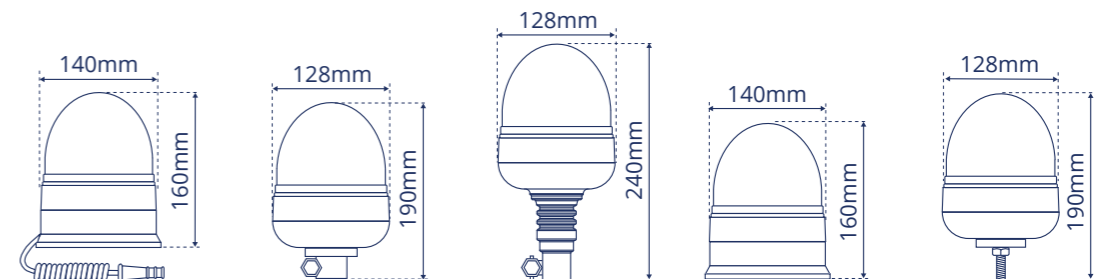

Part No.	<b>RMB020</b>	<b>RMB030</b>	<b>RMB040</b>	<b>RMB050</b>	<b>RMB060</b>
Fitting	Magnetic	DIN	Flexi DIN	3 Point	Single Point
Weight	0.7KG	0.6KG	0.6KG	0.5KG	0.5KG

# ROTATING AND LED 'AGRI' BEACONS (RCB040 Range)

**R10** 1 YEAR WARRANTY

With a Flexi-DIN mounting and available in Rotating and LED models, our low-cost RCB beacons are ideal for agricultural applications.



## Main Features - RCB040

**R65**

- Dual Voltage (12/24V)
- IP56 rated ingress protection
- Lightweight (560g)
- Supplied with 12V and 24V bulbs
- -15°C to +40°C extreme temperature reliability
- Maintenance free worm drive mechanism



## Main Features - RCB040LED

- Multi-voltage (10-30V)
- IP56 rated ingress protection
- Lightweight (560g)
- 40 LEDs that can operate in 3 selectable flash patterns – rotating, double flash and quad flash
- -15°C to +40°C extreme temperature reliability

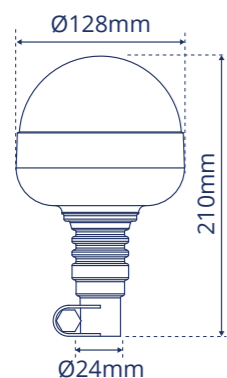

## Lens Colours Available



# LED R65 BEACONS (LFB Range)

**R65** **R10** 2 YEAR WARRANTY

The LFB range features a robust polycarbonate fresnel lens and 12 x 3W high performance LEDs that can operate in four flash patterns.



## Main Features

- Multi-voltage (10-30V)
- 70mph rated on magnetic version
- R65 approved for amber lens only
- IP56 rated ingress protection
- Nominal flash rate: 120 per minute
- 3-Point and single point models can be linked for synchronised flash
- Current consumption: 2.0A @ 12V / 1.3A @ 24V
- -30°C to +50°C extreme temperature reliability

*\*Double flash only on DIN and Flexi-DIN models*

## Lens Colours Available

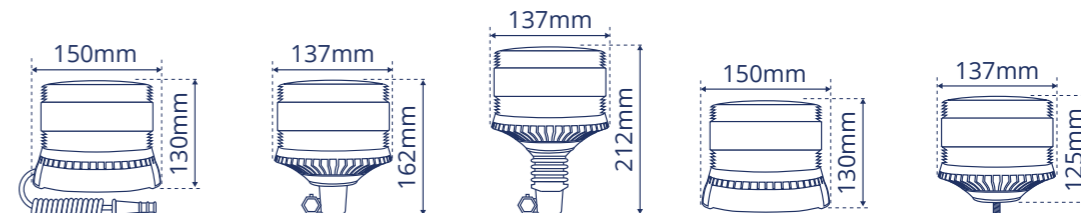

Part No.	LFB020	LFB030	LFB040	LFB050	LFB060
Fitting	Magnetic	DIN	Flexi DIN	3 Point	Single Point
Weight	1.2KG	0.7KG	0.9KG	0.7KG	0.7KG

## LED R65 BEACONS (LRB Range)



We have combined the latest LED technology with advanced optics to provide this unique ECE Reg 65 LED beacon. The powerful LEDs are arranged to produce a brilliant 360 degree flash pattern to provide superior light output for maximum visibility.



### Main Features

- Multi-voltage (10-30V)
- 70mph rated on magnetic version
- IP56 rated ingress protection
- Nominal flash rate: 120 per minute
- Very low power consumption
- Double flash
- Current consumption: 2.0A @ 12V / 1.3A @ 24V
- -30°C to +50°C extreme temperature reliability

### Lens Colours Available



Amber

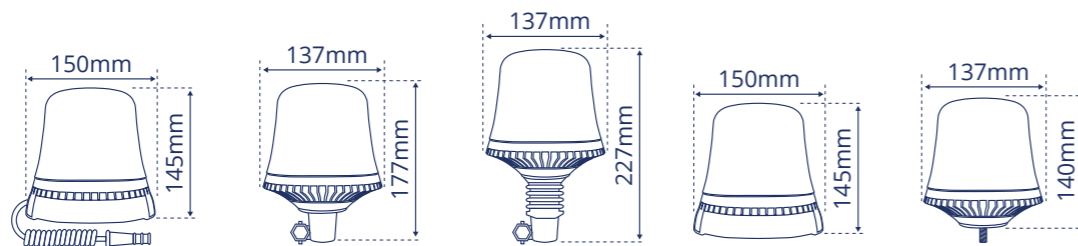

Part No.	LRB020	LRB030	LRB040	LRB050	LRB060
Fitting	Magnetic	DIN	Flexi DIN	3 Point	Single Point
Weight	1.4KG	0.9KG	1.1KG	0.9KG	0.9KG

## LED R65 BEACONS (LTB Range)



Our new economical LTB range combines 45 ultra-bright LEDs with advanced optics to provide R65 approved light output.



### Main Features

- Dual Voltage (12/24V)
- 40mph rated on magnetic version
- IP56 rated ingress protection
- 2 selectable flash patterns – double flash (R65 approved) and simulated rotating
- Current consumption: 2A @ 12V, 1A @ 24V
- -30°C to +50°C extreme temperature reliability

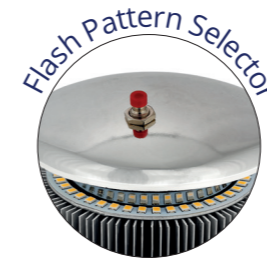

### Lens Colours Available



Amber



Green

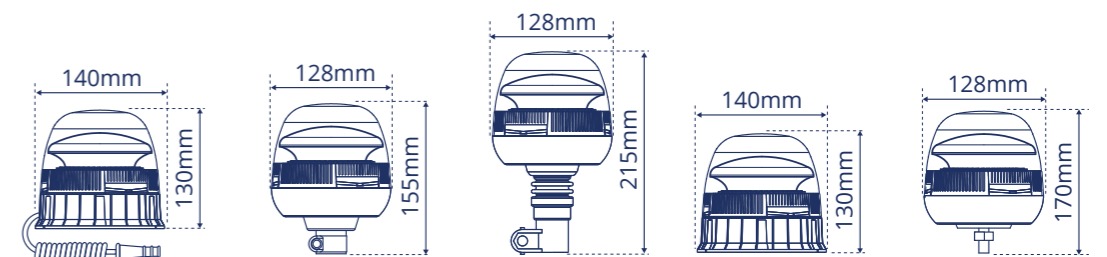

Part No.	LTB020	LTB030	LTB040	LTB050	LTB060
Fitting	Magnetic	DIN	Flexi DIN	3 Point	Single Point
Weight	0.8KG	0.7KG	0.8KG	0.7KG	0.7KG

# LED R65 LOW PROFILE BEACONS (LPB & LPBC Range)



The LPB Range features a low profile polycarbonate lens with a robust aluminium base and 12 x 3W high performance LEDs that can operate in three flash patterns including simulated rotating.



### Main Features

- Dual Voltage (12/24V)
- 70mph rated on magnetic version
- IP56 rated ingress protection
- Double flash & rotating patterns meet R65 (amber and clear models only)
- Current consumption: 1.8A @ 12V / 24V
- -30°C to +50°C extreme temperature reliability
- Clear lens model – amber flash LEDs



### Lens Colours Available



Part No.	LPB020	LPB040	LPB050	LPB060
Fitting	Magnetic	Flexi DIN	3 Point	Single Point
Weight	0.7KG	0.8KG	0.5KG	0.5KG

# LED COMPACT BEACONS (LCB Range)



Our LED Compact Beacons feature 4 x 4W high powered LEDs with advanced optics and are ideal for off-road use whilst also being suitable for a variety of vehicle applications.



### Main Features

- Multi-voltage (10-30V)
- 70mph rated on magnetic version
- IP56 rated ingress protection
- Nominal flash rate: 80 per minute
- Double flash
- Current consumption: 0.6A @ 12V / 0.3A @ 24V
- -30°C to +50°C extreme temperature reliability



### Lens Colours Available

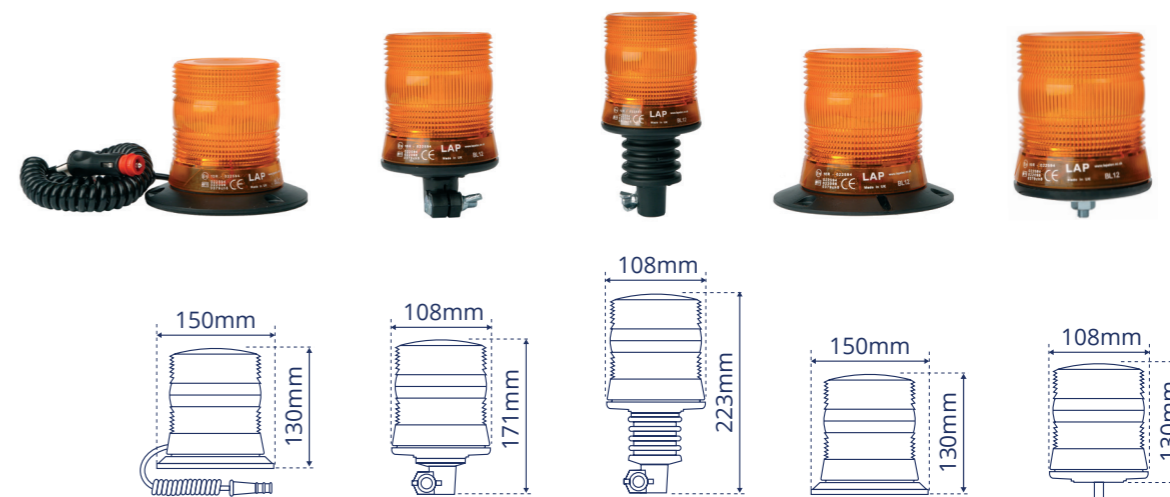

Part No.	LCB020	LCB030	LCB040	LCB050	LCB060
Fitting	Magnetic	DIN	Flexi DIN	3 Point	Single Point
Weight	1.0KG	0.5KG	0.6KG	0.4KG	0.4KG

## LED BEACONS (LMB Range)

Our mid-range LED LMB beacons feature 40 LEDs that can operate in three flash patterns including simulated rotating.



### Main Features

- Dual Voltage (12/24V)
- 40mph rated on magnetic version
- 70mph magnetic model available (LMB020X)
- IP65 rated ingress protection
- Nominal flash rate: 120 per minute (rotating) and 75 per minute (double & quad)
- Current consumption: 1.2A @ 12V / 0.6A @ 24V
- 3 selectable flash patterns - rotating, double flash and quad flash
- Fully encapsulated electronics



### Lens Colours Available



Part No.	LMB020	LMB030	LMB040	LMB050	LMB060
Fitting	Magnetic	DIN	Flexi DIN	3 Point	Single Point
Weight	0.6KG	0.5KG	0.5KG	0.4KG	0.5KG

## LED BEACONS (LSB Range)

Our LSB beacons are compact, economical and the multi-voltage model is ideal for material handling applications.

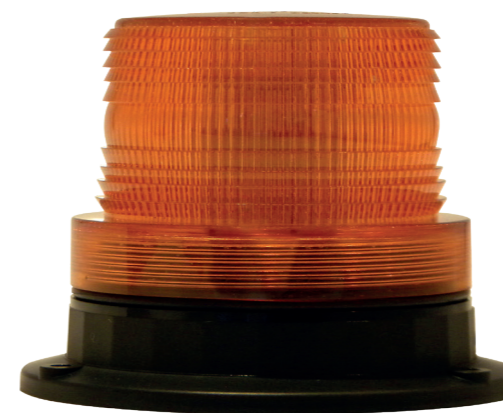

### Main Features

- Dual Voltage (12/24V) and Multi-voltage (10-110V) models
- 40mph rated on magnetic version
- IP56 rated ingress protection
- 40 ultra-bright SMD LEDs (60 on MV model)
- PCD of 117mm (3 point model)
- -30°C to +50°C extreme temperature reliability
- 2 selectable flash patterns - rotating and quad flash

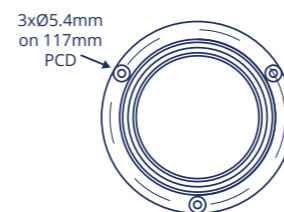

### Lens Colours Available

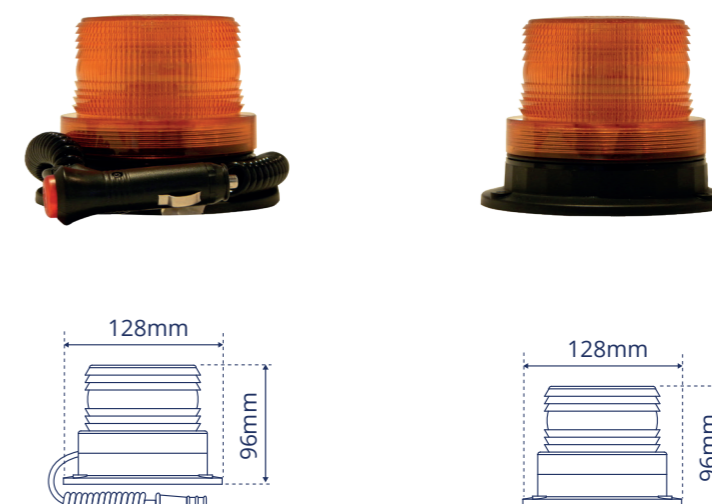

Part No.	LSB020	LSBMV050
Fitting	Magnetic	3 Point
Weight	0.6KG	0.3KG

## LED BEACONS (LLP and LLT Range)

R10 2 YEAR WARRANTY

Our high performance, low profile LED Beacons are a cost effective solution for working vehicles of all types that require supplementary warning light devices.



### Main Features

- Multi-voltage (10-100V)
- IP67 rated ingress protection
- Fully encapsulated electronics
- -30 to +50°C extreme temperature reliability
- Low power consumption (0.1 Amps)
- 4 flash patterns (static, single, double, quad)

### Lens Colours Available

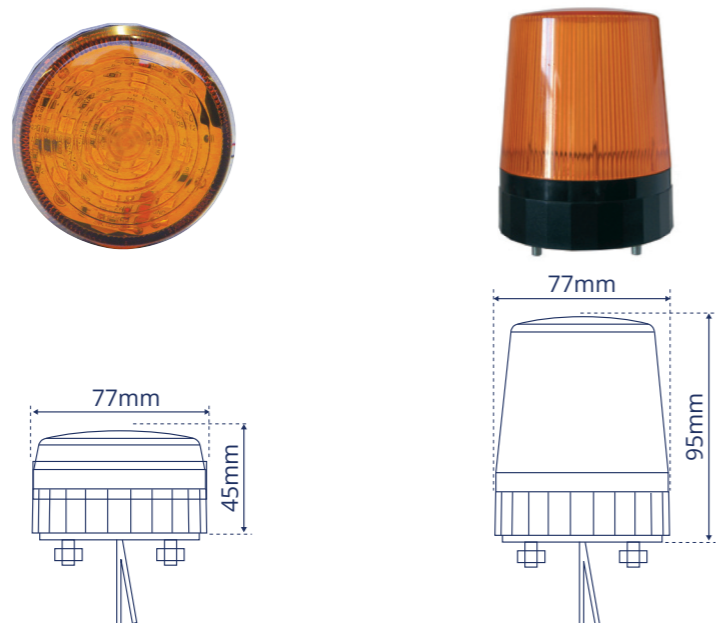

Part No.	<b>LLPMV</b>	<b>LLTMV</b>
Fitting	2 Point	2 Point
Weight	0.2KG	0.2KG

## HIGH POWER XENON BEACONS (XHP Range)

R65 R10 1 YEAR WARRANTY

Our high power xenon beacons feature advanced fresnel optics coupled with a 14 Watt high intensity xenon discharge lamp which provides ECE R65 approved visual warning in single and double flash modes.



### Main Features

- Dual Voltage (12/24V)
- 70mph rated magnetic version
- IP56 rated ingress protection
- Built-in option of either single or double flash
- Nominal flash rate: 125 per minute
- Current consumption: 2.0A @ 12V / 1.0A @ 24V
- -30°C to +50°C extreme temperature reliability

### Lens Colours Available

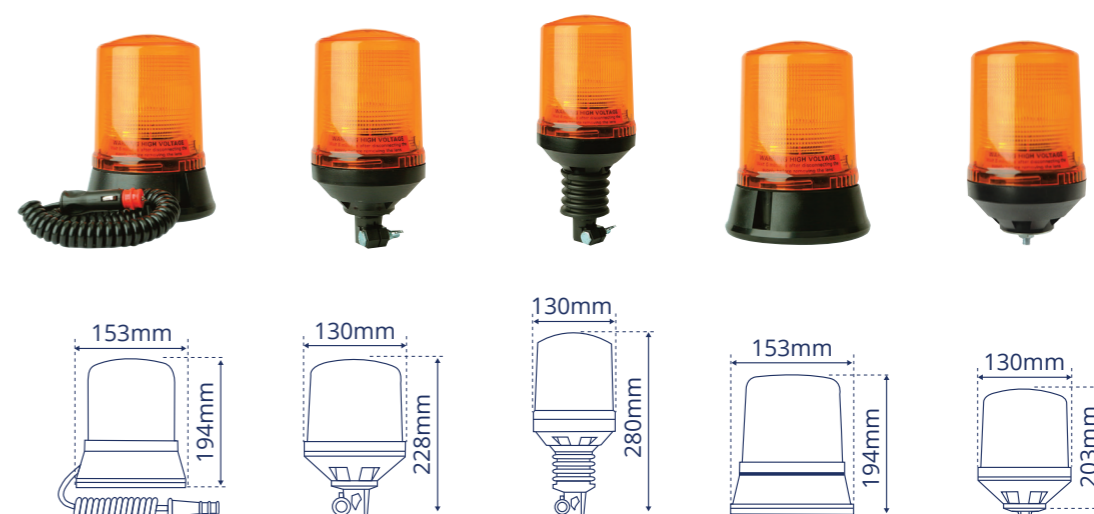

Part No.	<b>XHP020</b>	<b>XHP030</b>	<b>XHP040</b>	<b>XHP050</b>	<b>XHP060</b>
Fitting	Magnetic	DIN	Flexi DIN	3 Point	Single Point
Weight	1.4KG	0.9KG	1.0KG	0.8KG	0.9KG

ECE R65 Approval is appropriate to XHP range when beacons are operated in a single or double flash mode and fitted with either an Amber or Blue lens.

# XENON BEACONS (XNB Range)

With a 7 Watt xenon lamp and inner fresnel lens, our XNB range provides high brightness visual warning in single and double flash modes.



### Main Features

- Dual Voltage (12/24V)
- 70mph rated on magnetic version
- IP56 rated ingress protection
- Built-in option of either single or double flash
- Nominal flash rate: 125 per minute
- Current consumption: 1.6A @ 12V / 0.8A @ 24V
- -30°C to +50°C extreme temperature reliability

### Lens Colours Available

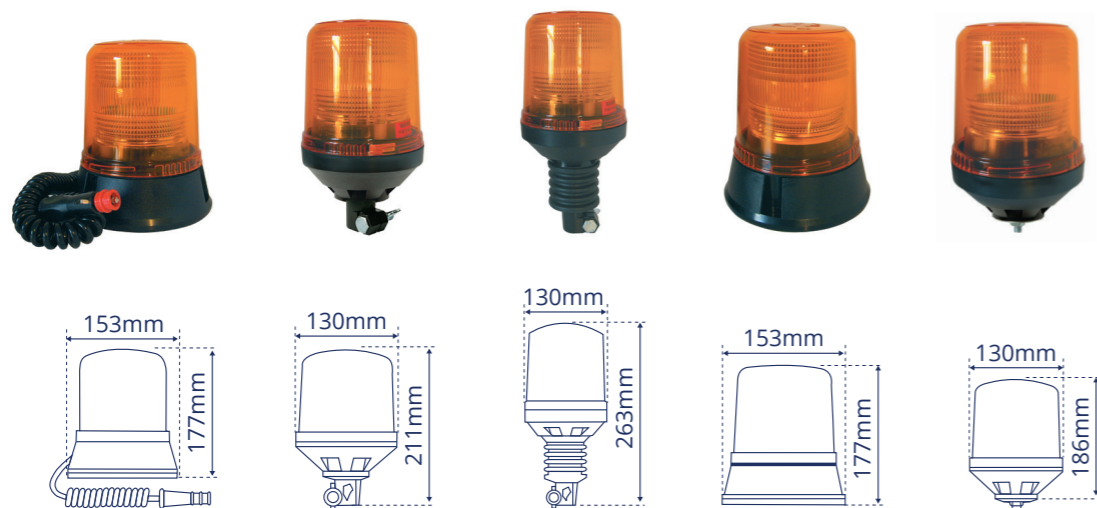

Part No.	<b>XNB020</b>	<b>XNB030</b>	<b>XNB040</b>	<b>XNB050</b>	<b>XNB060</b>
Fitting	Magnetic	DIN	Flexi DIN	3 Point	Single Point
Weight	1.4KG	0.9KG	1.0KG	0.8KG	0.9KG

# COMPACT XENON BEACONS (XCB Range)

Low power consumption and high durability make this range ideal for plant and contracting, agriculture, utility, fleet and forklift vehicles.



### Main Features

- Multi-voltage (10-100V)
- 70mph rated on magnetic version
- IP56 rated ingress protection
- Nominal flash rate: 75 per minute
- A choice of either 2 Watt or 6 Watt versions
- Sealed against dust and moisture ingress
- -30°C to +50°C extreme temperature reliability

### CURRENT CONSUMPTION (A)

Voltage	<b>12V</b>	<b>24V</b>	<b>48V</b>	<b>80V</b>	<b>100V</b>
2W Models	0.18	0.15	0.06	0.03	0.02
6W Models	0.46	0.40	0.22	0.13	0.10

Our popular compact xenon beacons are now 10-100V compatible making them ideal for off-road, on-road and material handling applications.

### Lens Colours Available

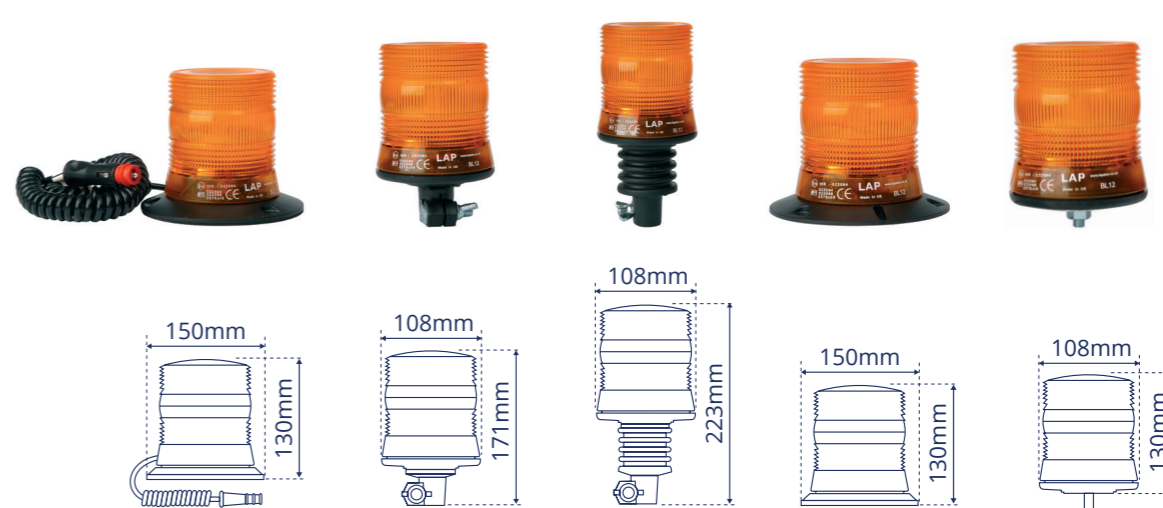

2W Model	<b>XCB0202</b>	<b>XCB0302</b>	<b>XCB0402</b>	<b>XCB0502</b>	<b>XCB0602</b>
6W Model	<b>XCB0206</b>	<b>XCB0306</b>	<b>XCB0406</b>	<b>XCB0506</b>	<b>XCB0606</b>
Fitting	Magnetic	DIN	Flexi DIN	3 Point	Single Point
Weight	1.0KG	0.5KG	0.6KG	0.4KG	0.4KG

## LOW PROFILE XENON BEACONS (DLP and DLT Range)

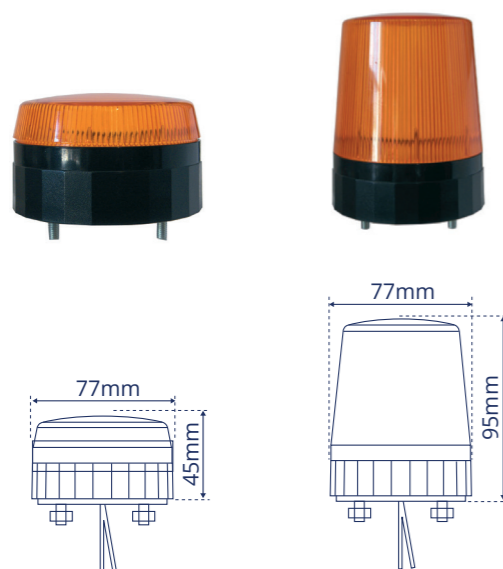
1 YEAR  
WARRANTY

### Main Features

- EMC approved
- Multi-voltage (10-100V)
- IP67 rated ingress protection
- 2 & 5 Watt versions
- -30 to +50°C extreme temperature reliability
- Nominal flash rate: 75 per minute
- Single flash

### Lens Colours Available



2W Model	<b>DLP2MVA</b>	<b>DLT2MVA</b>
5W Model	<b>DLP5MVA</b>	<b>DLT5MVA</b>
Fitting	2 Point	2 Point
Weight	0.2KG	0.2KG

CURRENT CONSUMPTION (A)						
Voltage	12V	24V	48V	80V	100V	
2W Models	0.18	0.16	0.12	0.09	0.07	
5W Models	0.26	0.23	0.15	0.12	0.01	

## MULTI-VOLTAGE XENON BEACONS (XCBMV Range)

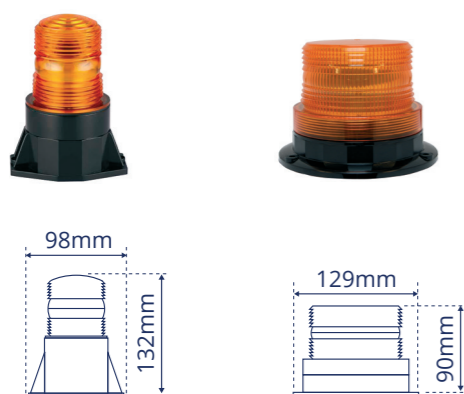
2 YEAR  
WARRANTY

### Main Features

- EMC approved
- Multi-voltage (10-80V)
- IP67 rated ingress protection
- -30 to +50°C extreme temperature reliability
- Nominal flash rate: 75 per minute

### Lens Colours Available



Part No.	<b>XCBMV2111</b>	<b>XCBMV1611</b>
Fitting	2 Point	3 Point
Weight	0.5KG	0.5KG

CURRENT CONSUMPTION (A)						
Voltage	12V	24V	48V	80V	100V	
2W Models	0.17	0.15	0.12	0.09	0.07	

## STATIC AIRPORT BEACONS

1 YEAR  
WARRANTY

### Main Features

- EMC approved
- 70mph rated on magnetic version
- 12V and 24V models available
- IP56 rated ingress protection
- Amber model conforms to CAP168 regulations
- Single flash
- Nominal flash rate: 80 flashes per minute
- Current consumption: 1.0A @ 12V, 0.5A @ 24V

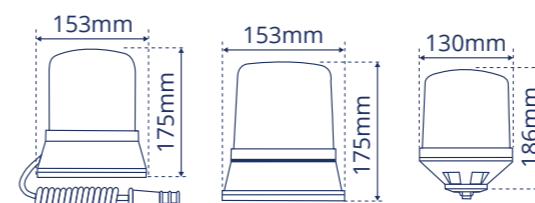

### Lens Colours Available



12V Model	<b>LAP223</b>	<b>LAP221</b>	<b>LAP225</b>
24V Model	<b>LAP224</b>	<b>LAP222</b>	<b>LAP226</b>
Fitting	Magnetic	3 Point	Single Point
Weight	1.2KG	0.6KG	0.9KG

## INDUSTRIAL BEACONS

1 YEAR  
WARRANTY

### Main Features

- IP56 rated ingress protection
- Dimensions: 153 (d) x 190 (h) mm
- 115Vac, 230Vac and 12/24Vdc versions
- Xenon Models - single/double flash
- Static flashing and rotating models - tungsten (115V & 230V) or halogen (12/24V) bulbs

### Lens Colours Available



	XENON	STATIC	ROTATING
115V Model	<b>LAP400</b>	<b>LAP411</b>	<b>LAP431</b>
230V Model	<b>LAP401</b>	<b>LAP412</b>	<b>LAP432</b>
12/24V Model	<b>LAP402</b>	<b>LAP462</b>	<b>LAP442</b>
Fitting	3 Point	3 Point	3 Point
Weight	0.8KG	0.7KG	0.9KG