

MINI LED LIGHTBARS (LAP1556 Range)

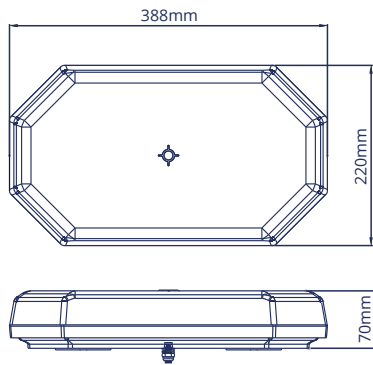

The LAP1556 LED lightbar is manufactured with 56 ultra-bright amber LEDs for excellent warning light.



Main Features

- Dual Voltage (12/24V)
- IP67 rated ingress protection
- Clear polycarbonate lens
- Current consumption: 4.7A @ 12V, 2.3A @ 24V
- 10 flash patterns
- Single flash pattern meets R65 approval
- 56 x 0.5W amber LEDs
- Single point fixing

MINI LED LIGHTBARS (LAP0930 Range)



The economical low profile LAP0930 range provides ultra bright hazard warning with 30 x 1W amber LEDs.



Model shown: LAP0930AC/MAG

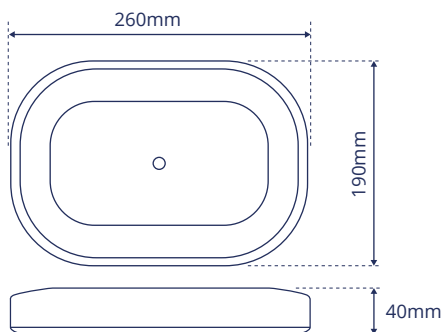

Main Features

- Dual Voltage (12/24V)
- IP67 rated ingress protection
- 40mph rated on magnetic version
- 11 flash patterns
- Clear polycarbonate lens

Part No	No. of Modules	No. of LEDs	LED Rating	Mounting
LAP0930AC/MAG	10	30	1W	Magnetic
LAP0930AC/SP	10	30	1W	Single Point